

Cole-Parmer®

CN-200 Series

Analogue Controllers

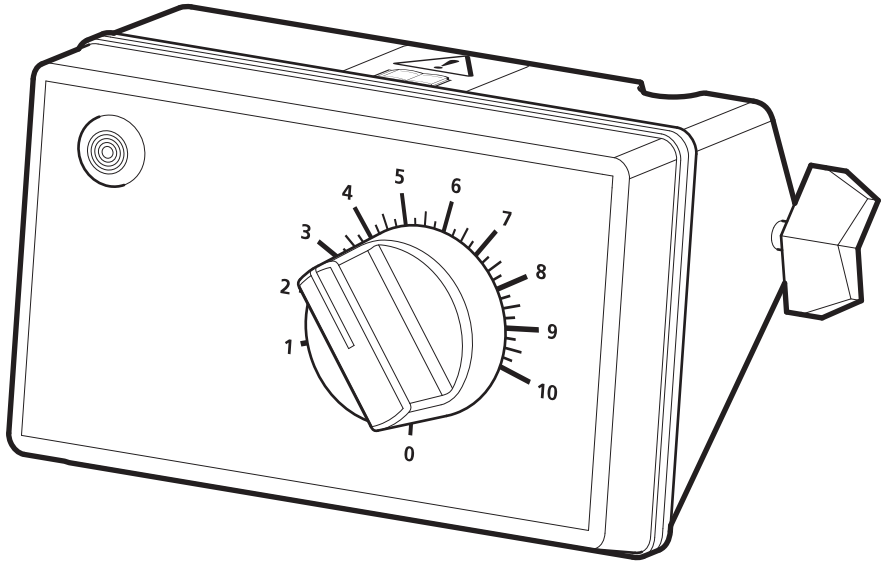

Instruction Manual
M7759 Version 3.5

Cole-Parmer®
essentials

Please take your time to read this Instruction manual in order to understand the safe and correct use of your new Cole-Parmer product.

It is recommended the responsible Body for the use of this equipment reads this instruction manual and ensures the user(s) are suitably trained in its operation.

Contents	Page
Section 1 Introduction	3
Section 2 Symbols and using this Instruction Manual	4
Section 3 Safety Information	5
Section 4 Unpacking and Contents	7
Section 5 Installation	8
Section 6 Environmental Protection	9
Section 7 Equipment Operation	10
Section 8 Technical Specification	12
Section 9 Maintenance	13
Section 10 Spares and Accessories	15
Section 11 Customer and Technical Support	16
Section 12 Notes	17
Section 13 EU Declaration of Conformity	19

© The copyright of this instruction manual is the property of Antylia Scientific Limited. This instruction manual is supplied by Antylia Scientific Limited on the express understanding that it is to be used solely for the purpose for which it is supplied. It may not be copied, used or disclosed to others in whole or part for any purpose except as authorised in writing by Antylia Scientific Limited. Antylia Scientific Limited reserves the right to alter, change or modify this document without prior notification.

In the interest of continued development Antylia Scientific Limited reserve the right to alter or modify the design and / or assembly process of their products without prior notification.

This product is manufactured in Great Britain by Cole-Parmer, part of the Antylia Scientific Group of companies.

Antylia Scientific Ltd.

Beacon Road,
Stone,
Staffordshire,
ST15 0SA,
United Kingdom
Tel: +44 (0)1785 812121

1. INTRODUCTION

- 1.1. CN-200-2300 is a 230 V ~ AC controller. The CN-200-1100-115 is a 115 V ~ AC controller.
- 1.2. This series of Power Controllers have been designed to regulate the power input to laboratory heating equipment. These controllers can be mounted on a standard ½" (12mm) dia scaffold or retort stand or they can also be wall mounted using a mounting bracket or stand directly on the bench.

2. SYMBOLS AND USING THIS INSTRUCTION MANUAL

- 2.1. Throughout this Instruction manual the following symbols are shown to identify conditions which pose a hazard to the user, or to identify actions that should be observed. These symbols are also shown on the product, or its packaging. When a symbol is shown next to a paragraph or statement it is recommended the user takes particular note of that instruction in order to prevent damage to the equipment or to prevent injury to one's self or other people.

The Responsible Body and the Operator should read and be familiar with this Instruction manual in order to preserve the protection afforded by the equipment.

To prevent injury or equipment damage it is the manufacturer's recommendation that all persons using this equipment are suitably trained before use.

2.2. Symbols Defined.



Caution, risk of danger. See note or adjacent symbol.



Protective conductor terminal to be earthed.
(Do not loosen or disconnect).



Caution / Risk of electric shock.



Recyclable Packaging Material.



Do not dispose of product in normal domestic waste.



Bio Chemical Hazard. Caution required. May require decontamination.



Refer to Instruction manual.



Input mains terminal.



Output mains terminal.

3. SAFETY INFORMATION

This product has been designed for safe operation when used as detailed in accordance with the manufacturer's instructions.

NOTE: Failure to use this equipment in accordance with this instruction manual may compromise your basic safety protection afforded by the equipment and may invalidate the warranty / guarantee. The warranty / guarantee does not cover damaged caused by faulty installation or misuse of the equipment.

3.1. Prevention of Fire and Electric shock.

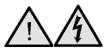

To prevent a risk of fire or electric shock, **do not** open your product case without authorisation. Only qualified Service personnel should attempt to repair this Controller.



Only replace fuses with the type as listed in Technical Specification section (See fuse type and rating).

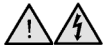

Ensure the Mains Power Supply conforms to rating found on the data plate located on the base of this product.



Never operate this equipment without connection to earth / ground. Ensure the mains supply voltage is correctly earthed / grounded in accordance with current area legislation.



Do not install or remove any heating apparatus from the controller whilst power is applied.

3.2. General Safe Operating Practice.



Always follow good laboratory practice when using this Equipment. Give due recognition to your company's safety and legislative health & safety procedures and all associated legislation applicable to your areas of operation. Check laboratory procedures for substances being heated and ensure all hazards (e.g. explosion, implosion or the release of toxic or flammable gases) that might arise have been suitably addressed before proceeding. When heating certain substances the liberation of hazardous gases may require the use of a fume cupboard or other means of extraction.



Ensure equipment is used on a clean, dry, non-combustible, solid work surface with at least 300mm suitable clearance all around from other equipment.



Do not position the product so that it is difficult to disconnect from the mains supply.



Do not immerse the controller in water or fluids.



Do not spill substances onto this unit. If spillage does occur, disconnect unit from mains supply and follow instructions as detailed in Section 'Maintenance'.



To prevent electronic overheat and potential fire, **do not** cover this product when connected to the mains power supply.



It is **not** recommended to leave any heating apparatus unattended during operation.



Only use original equipment manufacturer's spares and accessories. Refer to section 10.



The equipment is not spark, flame or explosion proof and has not been designed for use in hazardous areas in terms of BSEN 60079-14:1997. Keep flammable, low flash point substances away from heating apparatus.



Do not operate or handle any part of this product with wet hands.



Keep the mains plug and lead set cable away from the heating apparatus being controlled.



Refer to instruction manual for the resistive load of equipment to ensure controller is suitable for application.



Always observe the manufacturer's operating and safety instructions for the equipment to be connected to the controller.

NOTE: *if this product is not used in accordance with the manufacturer's instructions then the basic safety protection afforded by the equipment may not be preserved and the guarantee invalidated.*

4. UNPACKING AND CONTENTS

4.1. Please check the contents of your carton against the diagram.

(Please note CN-200-2300 & CN-200-1100-115 has a hard wired input).

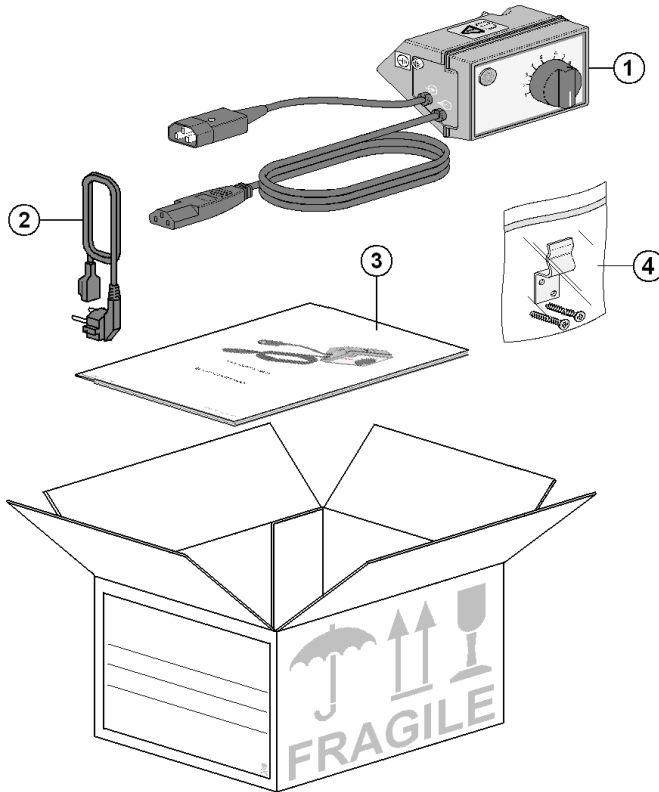

Item	Contents. Description	Qty
1	CN-200-2300 & CN-200-1100-115 Control unit	1
2	Moulded mains cord and plug set. (Input) <i>(May be different to illustration).</i>	A/R
3	Instructions book (this document).	1
4	Wall fixing Bkt and screws x 2 – per bag.	1

<p>or future reference please record your products Serial and Model Numbers.</p>	<p>Serial Number</p>	<p>Model Number</p>
--	-----------------------------	----------------------------

5. INSTALLATION

5.1. Electrical safety and Installation

5.2. This equipment is designed for safe operation under the following conditions:-

- Indoor use.
- Altitude up to 2000 meters.
- Temperatures between 5°C and 40°C.
- Maximum relative humidity 80% for temperatures up to 31°C decreasing linearly to 50% relative humidity at 40°C.
- Mains supply voltage fluctuations up to $\pm 10\%$ of the nominal voltage.
- Transient overvoltages typically present on the mains supply. (Overvoltage category II).
- Applicable rated pollution degree 2.

5.3.  This equipment must be earthed / grounded to a fixed earth / grounded mains socket outlet. The mains supply is to be earthed / grounded in accordance with current legislation.

5.4. Ensure only the correct rated mains input fuses are fitted. (Where applicable ensure the correct mains cable fuse if fitted). See Technical Specification, Section 8 of this Instruction manual.

5.5. Check the voltage on the product data label of this unit. Ensure the rating conforms to your local supply. If an 115V product is used in a 230V supply area, then a 230/115V transformer must be installed between the 230V mains supply and the product, by a competent electrician.

Only connect controller to resistive loads. Refer to sub-section 8.1.

5.6. It is recommended this unit be connected to a mains supply source which incorporates an RCD or GFCI device.

The unit is supplied with a moulded mains cord and plug set wired as follows:-

Green /Yellow or Green = Earth / Ground 

Blue or White = Neutral

Brown or Black = Live / line hot.

5.7. If the controller is to be used on a retort rod, make sure it isn't positioned over any heating apparatus.

6. ENVIRONMENTAL PROTECTION

6.1. Maximum consideration has been given to environmental issues within the design and manufacturing process without compromising end product performance and value.

6.2.  Packaging materials have been selected such that they may be sorted for recycling.

6.3.  At the end of your product and accessories life, it must **not be** discarded as domestic waste. Ref: EU Directive 2002/96/EC on Waste Electrical and Electronic Equipment Directive (WEEE). Please contact your distributor / supplier for further information. For end users outside of the EU consult applicable regulations.

6.4. This product should only be dismantled for recycling by an authorised recycling company.



This product and accessories must be accompanied by a completed Decontamination Certificate prior to any Disposal. Copies of the Certificate are available from Distributor/Manufacturer.

7. EQUIPMENT OPERATION

7.1. The illustrations below show a detailed layout of the CN-200-2300 & CN-200-1100-115 control unit.

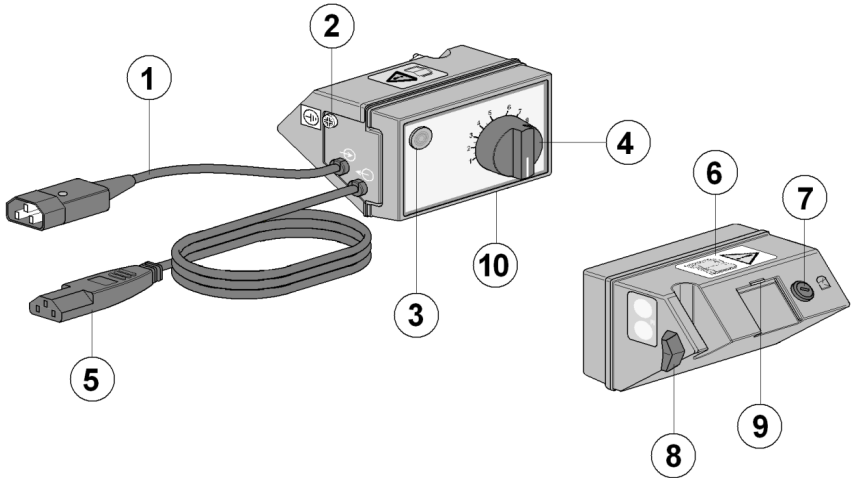

230V illustration

- 1 Mains Input socket.
- 2 Earth continuity test point
- 3 Controlled appliance heaters on neon lamp. (*Amber*).
- 4 Regulator control knob.
- 5 Mains output – connection to appliance
- 6 Refer to instruction manual.
- 7 Fuse holder
(*See section 8 & 11 for further information*).
- 8 Rod support clamp.
- 9 Support clip.
- 10 Dataplate label. (*See for correct voltage type*).

Check the Dataplate label and ensure your mains electrical supply voltage is compatible with this product.

7.2. Connect the IEC output plug from the controller to your heating apparatus product as illustrated.

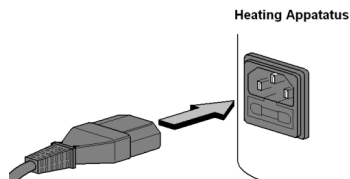

The CN-200-2300 & CN-200-1100-115 controllers can be used with the following Cole-Parmer products:

- HM-200 & SHM-200 Series Cole-Parmer Electromantles
- CMU, CMUT, CMUA, CMUV Series Electrothermal Electromantles

- 7.3. Connect to the mains electricity supply.
- 7.4. Switch the controller on by turning the regulator control knob clockwise to increase power. The amber neon lamp on the controller will pulsate to show that power is being supplied to the mantel, heating tape etc. The frequency of the pulse will increase as the regulator control knob setting is increased. At maximum setting the amber neon will be continually illuminated.
- 7.5. When your process is complete, switch off the controller and disconnect it from the mains electricity supply.
- 7.6.  For safe operating practice always refer to the Instruction manual of the equipment being used.

8. TECHNICAL SPECIFICATION

Mains supply voltage CN-200-2300	- 230V AC 50/60 Hz
Mains supply voltage CN-200-1100-115	- 115V AC 50/60 Hz
Maximum coupled power consumption 230V	2300 Watts
Maximum coupled power consumption 115V	1100 Watts
Controller power consumption	<1 Watt
Fuse rating	F10A 6x32mm quick blow (250V) F10A 6x32mm quick blow (115V / 250V)
HH179(S)	Mains cord and moulded IEC plug and lead set cable (UK) 10A BS1362
HH180(S)	Mains cord and moulded IEC plug and lead set cable (Europe)
CRM6288	Mains cord and moulded IEC plug and lead set cable (USA)
M7079	Mains cord and moulded IEC plug and lead set cable (Australia)

The Ingress Protection rating for this product is classified as IPX 0.



Do not allow this product to come into contact with liquid.

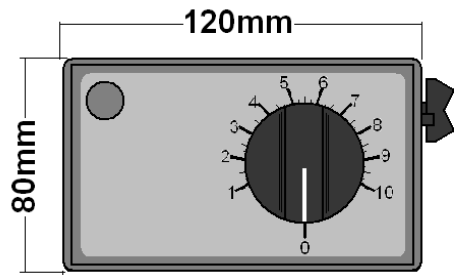
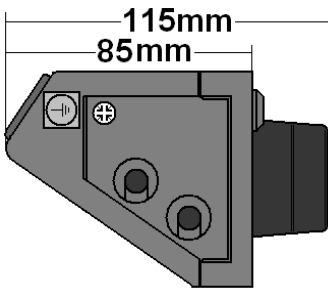

Weight 0.82 Kg

9. MAINTENANCE

9.1. General Information.



Unplug the unit from the mains voltage supply and allow it to cool before undertaking any maintenance tasks.



Maintenance should only be carried out under the direction of the Responsible Body, by a competent electrician. Failure to do so may result in damage to the product and in extreme cases be a danger to the end user.

With proper care in operation this equipment has been designed to give many years of reliable service. Contamination or general misuse will reduce the effective life of this product and may cause a hazard.

Maintenance for the unit should include:

- Periodic electrical safety testing (an annual test is recommended as the minimum requirement).
- Regular inspection for damage with particular attention to the mains lead and plug set.
- Routine cleaning of the equipment should be undertaken using a clean cloth.

DO NOT USE SOLVENTS FOR CLEANING ANY PART OF THIS EQUIPMENT.

9.2. Replacing controller fuse.

CN-200-2300 & CN-200-1100-115

1. Unscrew the fuse holder cap from the fuse housing.
2. Remove the fuses. Fit replacement fuses of the correct rate and value. Refer to 'Fuse Rating' in the Technical Specification section for correct fuse type and rating.

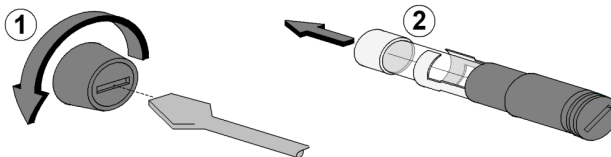

9.3. Spillage and Decontamination.

In the event of spillage switch off and unplug this product from the mains electrical supply. Wipe off all excess liquid from the unit and surrounding area using an absorbent soft cloth.

If in doubt please consult Customer Support. Refer to section 11.



If the equipment has been exposed to contamination, the Responsible Body is responsible for carrying out appropriate decontamination. If hazardous material has been spilt on or inside the equipment, decontamination should only be undertaken under the control of the Responsible Body with due recognition of possible hazards. Before using any cleaning or decontamination method, the Responsible Body should check with the manufacturer the proposed method will not damage the equipment.

Prior to further use, the Responsible Body shall check the electrical safety of the unit. Only if all safety requirements are met can the unit be used again. The above procedure is intended as a guide. Should spillage occur with a toxic or hazardous fluid then special precautions may be necessary.

Decontamination Certificate.

Note: In the event of this equipment or any part of the unit becoming damaged, or requiring service, the item(s) should be returned to the manufacturer for repair accompanied by a completed decontamination certificate. **Copies of the Certificate are available from Distributor/Manufacturer.**

At the end of life, this product must be accompanied by a completed Decontamination Certificate.

10. SPARES AND ACCESSORIES

Order Number	Description
CRM5608	Neon amber (230V)
CRM5620	Neon amber (115V)
AZ9127	Energy regulator (230V)
AZ9128	Energy regulator (115V)
AZ6704	Mounting bracket kit
HH179(S)	Mains cord and moulded IEC plug and lead set cable (UK) 10A BS1362
HH180(S)	Mains cord and moulded IEC plug and lead set cable (Europe)
CRM6288	Mains cord and moulded IEC plug and lead set cable (USA)
M7079	Mains cord and moulded IEC plug and lead set cable (Australia)

Please contact your local sales specialist or email cpspares@antylia.com to enquire about available spares.

Please visit www.Cole-Parmer.com for a full list of available accessories.

11. CUSTOMER AND TECHNICAL SUPPORT

For help and support in using this product, please contact Customer Services at the following address:

Antylia Scientific Ltd.
Beacon Road,
Stone,
Staffordshire,
ST15 0SA,
United Kingdom
Tel: +44 (0)1785 812121

Service: cpervice@antylia.com
General enquiries: cpinfo@antylia.com
Order enquiries: cpsales@antylia.com
Technical support: cptechsupport@antylia.com

www.coleparmer.com

12. NOTES

12. NOTES

**CE UK
CA** This product meets the applicable CE Directives and UKCA Legislation for radio frequency interference and may be expected not to interfere with, or be affected by, other equipment with similar qualifications. We cannot be sure that other equipment used in its vicinity will meet these standards and so we cannot guarantee

that interference will not occur in practise. Where there is a possibility that injury, damage or loss might occur if equipment malfunctions due to radio frequency interference, or for general advise before use, contact the manufacturer.

Declaration of Conformity is available to view online at www.coleparmer.com

EU Representative address

Antylia Scientific GmbH
Futtererstraße 16
97877 Wertheim
Deutschland
Tel: +49 9377 9203-0
Email: sales@coleparmer.de

UK Representative address

Antylia Scientific
9 Orion Court
Ambuscade Road
Colmworth Business Park
St. Neots
PE19 8YX
United Kingdom
Tel: +44 (0) 1480 277339
Email: enquiries@antylia.com

Ordering Information

Order No.	Series	Model	Legacy SKU
36223-00	CN-200	CN-200-2300	MC227
36223-01	CN-200	CN-200-1100-115	MC228X1

Warranty Registration



UK

T: +44 (0) 1480 272279
E: uk.sales@antylia.com
W: coleparmer.co.uk

Germany

T: +49 (0) 9377 92030
E: de.sales@antylia.com
W: coleparmer.de

France

T: +33 (0) 1486 37800
E: fr.sales@antylia.com
W: coleparmer.fr

Italy

T: +39 (0) 284349215
E: it.sales@antylia.com
W: coleparmer.it

India

T: +9122 61394444
E: info@coleparmer.in
W: coleparmer.in

China

T: +1 847 549 7600
E: sales@antylia.com
W: coleparmer.com

USA

T: +1 847 549 7600
E: sales@antylia.com
W: coleparmer.com

Canada

T: +514 355 6100
E: info@antylia.ca
W: coleparmer.ca

Other

T: +1 847 549 7600

Cole-Parmer®
essentials

Antylia Scientific Ltd.
Beacon Road,
Stone,
Staffordshire,
ST15 0SA,
United Kingdom

