

Cole-Parmer®

CN-200D Series Digital Controllers

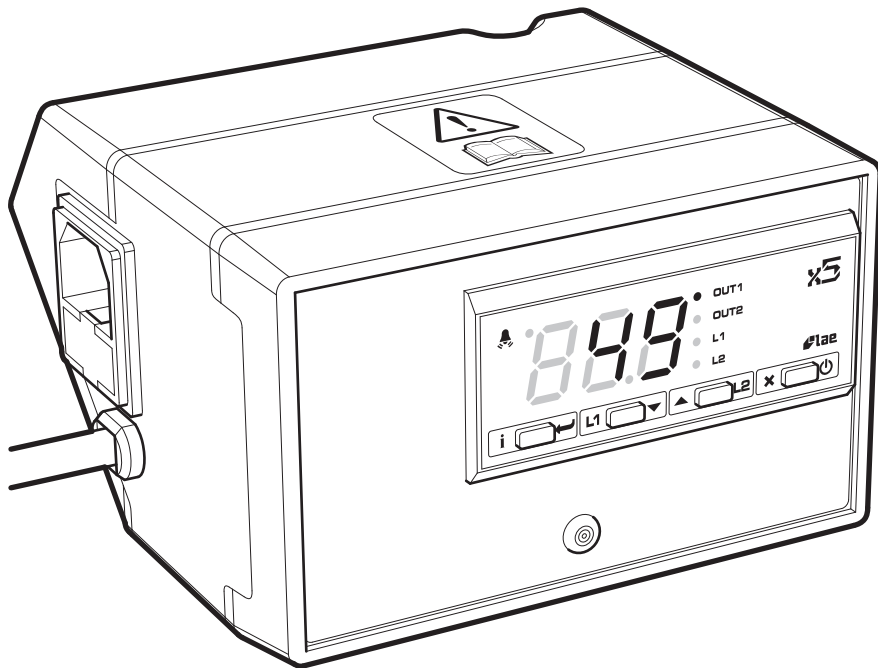

Instruction Manual
M6493 Version 10.6

Cole-Parmer®
essentials

Please take your time to read this Instruction manual in order to understand the safe and correct use of your new Cole-Parmer product.

It is recommended the responsible Body for the use of this equipment reads this instruction manual and ensures the user(s) are suitably trained in its operation.

Contents	Page
Section 1 Introduction	3
Section 2 Symbols and using this Instruction Manual	4
Section 3 Safety Information	5
Section 4 Unpacking and Contents	7
Section 5 Installation	8
Section 6 Environmental Protection	9
Section 7 Equipment Operation	10
Section 8 Technical Specification	18
Section 9 Maintenance	19
Section 10 Spares and Accessories	21
Section 11 Customer and Technical Support	21
Section 12 Notes	22
Section 13 Declaration of Conformity	23

© The copyright of this instruction manual is the property of Antylia Scientific Limited. This instruction manual is supplied by Antylia Scientific Limited on the express understanding that it is to be used solely for the purpose for which it is supplied. It may not be copied, used or disclosed to others in whole or part for any purpose except as authorised in writing by Antylia Scientific Limited. Antylia Scientific Limited reserves the right to alter, change or modify this document without prior notification.

In the interest of continued development Antylia Scientific Limited reserve the right to alter or modify the design and / or assembly process of their products without prior notification.

This product is manufactured in Great Britain by Cole-Parmer, part of the Antylia Scientific Group of companies.

Antylia Scientific Ltd.

Beacon Road,
Stone,
Staffordshire,
ST15 0SA,
United Kingdom
Tel: +44 (0)1785 812121

1. INTRODUCTION

- 1.1. The Cole-Parmer CN-200D Digital Controller provides a convenient means of temperature control, using microprocessor techniques to give ease of operation and good accuracy. It can be used either in ON/OFF mode with the hysteresis loop controlling power switching or it can be used as a PID (Proportional, Integrated, Derivative) controller. Alternatively it may be used simply as a temperature measuring device.
- 1.2. Temperature sensing is performed by a plug-in platinum resistance probe. The sample temperature is displayed on the LED display. This product is suitable for bench and retort stand mounting or wall mounting using the bracket and screws provided.
- 1.3. The CN-200D has a short mains output lead with an IEC socket to connect it to the resistive load. An accessory extension mains lead is available where remote operation is required (e.g. in a fume extraction unit).
- 1.4. The CN-200D controller must be used in conjunction with a suitable heating or cooling device e.g. mantle, electric Bunsen or hotplate. For cooling applications please contact your distributor / supplier or contact Antylia Scientific at the address in section 11. Customer Support.

2. SYMBOLS AND USING THIS INSTRUCTION MANUAL

- 2.1. Throughout this Instruction manual the following symbols are shown to identify conditions which pose a hazard to the user, or to identify actions that should be observed. These symbols are also shown on the product, or its packaging. When a symbol is shown next to a paragraph or statement it is recommended the user takes particular note of that instruction in order to prevent damage to the equipment or to prevent injury to one's self or other people.

The Responsible Body and the Operator should read and be familiar with this instruction manual in order to preserve the protection afforded by the equipment.

To prevent injury or equipment damage it is the manufacturer's recommendation that all persons using this equipment are suitably trained before use.

2.2. Symbols Defined.



Caution, risk of danger. See note or adjacent symbol.



Protective conductor terminal to be earthed.
(Do not loosen or disconnect).



Caution / Risk of electric shock.



Recyclable Packaging Material.



Do not dispose of product in normal domestic waste.



Bio Chemical Hazard. Caution required. May require decontamination.



Refer to Instruction manual.



Info / Enter button



Modify Setpoint 1 / Decrease button



Increase / Modify Setpoint 2 button.



Exit / Standby button.



Alarm (This feature is not available on CN-200D).

3. SAFETY INFORMATION

This product has been designed for safe operation when used as detailed in accordance with the manufacturer's instructions.

NOTE: Failure to use this equipment in accordance with this instruction manual may compromise your basic safety protection afforded by the equipment and may invalidate the warranty / guarantee. The warranty / guarantee does not cover damaged caused by faulty installation or misuse of the equipment.

3.1. Prevention of Fire and Electric shock.

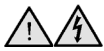

To prevent a risk of fire or electric shock, **do not** open your product case without authorisation. Only qualified Service personnel should attempt to repair this Controller.



Only replace fuses with the type as listed in Technical Specification section (See fuse type and rating).

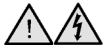

Ensure the Mains Power Supply conforms to rating found on the data plate located on the base of this product.

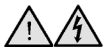

Never operate this equipment without connection to earth / ground. Ensure the mains supply voltage is correctly earthed / grounded in accordance with current area legislation.



Do not install or remove any heating apparatus from the controller whilst power is applied.

3.2. General Safe Operating Practice.



Always follow good laboratory practice when using this equipment. Give due recognition to your company's safety and legislative health & safety procedures and all associated legislation applicable to your areas of operation. Check laboratory procedures for substances being heated and ensure all hazards (e.g. explosion, implosion or the release of toxic or flammable gases) that might arise have been suitably addressed before proceeding. When heating certain substances the liberation of hazardous gases may require the use of a fume cupboard or other means of extraction.



Ensure equipment is used on a clean, dry, non-combustible, solid work surface with at least 300mm suitable clearance all around from other equipment.



Do not position the product so that it is difficult to disconnect from the mains supply.



Do not immerse the controller in water or fluids.



Do not spill substances onto this unit. If spillage does occur, disconnect unit from mains supply and follow instructions as detailed in Section 'Maintenance'.



To prevent electronic overheat and potential fire, **do not** cover this product when connected to the mains power supply.



It is **not** recommended to leave any heating apparatus unattended during operation.



Only use original equipment manufacturer's spares and accessories. Refer to Section 10.



The equipment is not spark, flame or explosion proof and has not been designed for use in hazardous areas in terms of BSEN 60079-14:1997. Keep flammable, low flash point substances away from heating apparatus.



Do not operate or handle any part of this product with wet hands. Keep the Mains Plug and Lead set cable away from the heating apparatus being controlled.



Refer to Instructions manual / product data label for the resistive load of equipment to ensure controller is suitable for application.



Always observe the manufacturer's operating and safety instructions for the equipment to be connected to the controller.

NOTE: *if this product is not used in accordance with the manufacturer's instructions then the basic safety protection afforded by the equipment may not be preserved and the guarantee invalidated.*

4. UNPACKING AND CONTENTS

Item No	Description	Qty
1	Mains cord and moulded IEC plug and lead set. (May be different from illustration).	As Req
2	CN-200D Digital Controller.	1
3	Instruction Book	1
4	Wall fixing Bkt x 1 and screws x 2 – per bag.	1
5	Temperature Probe	1

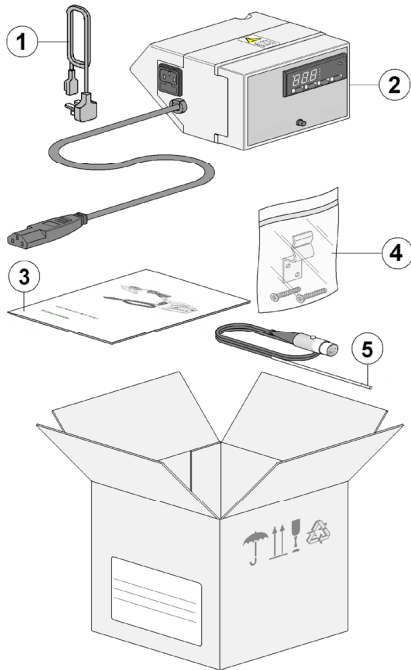

<p>For future reference please record your products Serial and Model Numbers.</p>	<p><i>Serial Number</i></p>	<p><i>Model Number</i></p>
--	-----------------------------	----------------------------

5. INSTALLATION

5.1. Electrical safety and Installation

5.2. This equipment is designed for safe operation under the following conditions:-

- Indoor use.
- Altitude up to 2000 meters.
- Temperatures between -10°C and +50°C.
- Maximum relative humidity 80% for temperatures up to 31°C decreasing linearly to 50% relative humidity at 40°C.
- Mains supply voltage fluctuations up to $\pm 10\%$ of the nominal voltage.
- Transient overvoltages typically present on the mains supply. (Overvoltage category II).
- Applicable rated pollution degree 2.

5.3.  This equipment must be earthed / grounded to a fixed earth / grounded mains socket outlet. The mains supply is to be earthed / grounded in accordance with current legislation.

5.4. Ensure only the correct rated mains input fuses are fitted. (Where applicable ensure the correct mains cable fuse if fitted). See Technical Specification, Section 8 of this Instruction manual.

5.5. Check the voltage on the product data label of this unit. Ensure the rating conforms to your local supply. Only connect to resistive loads = 2000Watts @ 230V~AC or 1000Watts @ 115V~AC. Refer to Technical Specification, Section 8 of this Instruction manual.

5.6. This product must be connected to a mains supply source which incorporates an RCD or GFCI device.

5.7. The unit is supplied with a moulded mains cord and plug set wired as follows:-

Green /Yellow or Green = Earth / Ground 



Blue or White = Neutral

Brown or Black = Live / line hot.

5.8. If the controller is to be used on a retort rod, make sure it isn't positioned over any heating apparatus.

5.9.  If using the wall mounting bracket provided, carefully mark and drill two suitable holes using the bracket as a template. Ensure there are no cables etc buried in the wall. Plug the holes with suitable rawl plugs (not supplied) and fasten the bracket to the wall in the correct orientation using the screws provided. Place the controller over the bracket.

6. ENVIRONMENTAL PROTECTION

- 6.1. Maximum consideration has to be given to environmental issues within the design and manufacturing process without compromising end product performance and value.
- 6.2.  Packaging materials have been selected such that they may be sorted for recycling.
- 6.3.  At the end of your product and accessories life, it must **not be** discarded as domestic waste. Ref: EU Directive 2002/96/EC on Waste Electrical and Electronic Equipment Directive (WEEE). Please contact your distributor / supplier for further information. For end users outside of the EU consult applicable regulations.
- 6.4. This product should only be dismantled for recycling by an authorised recycling company.



This product and accessories must be accompanied by a completed Decontamination Certificate prior to any Disposal. Copies of the Certificate are available from Distributor/Manufacturer.

7. EQUIPMENT OPERATION

7.1. The CN-200D controller has been designed for easy operation. The illustrations below show detailed layouts of this control unit.

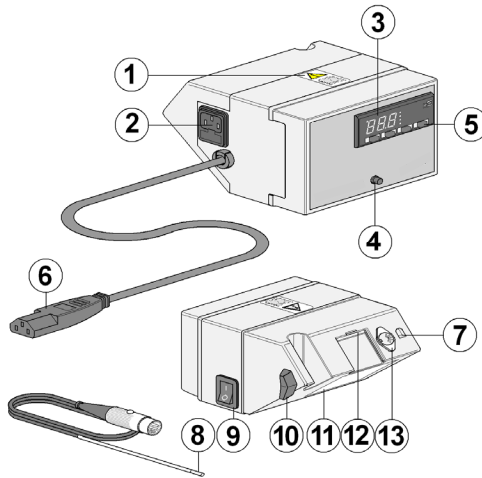

- 1 Instruction Manual label (refer to this Manual).
- 2 Mains input IEC socket with fuses.
- 3 3 digit LED display
- 4 Orange Neon power on indication lamp.
- 5 Exit / Standby button
- 6 Mains Output IEC plug.
- 7 Earth protective conduct terminal.
- 8 Temperature probe
- 9 On / Off, I/O power switch.
- 10 Retort rod clamp
- 11 Data plate label
- 12 Wall bracket clamp.
- 13 5 Pin DIN socket for temperature probe.

Check the data plate label and ensure your mains electrical supply voltage is compatible with this product.

7.2. Connection

7.2.1. Plug in the temperature probe to the 5 pin DIN socket. Place the temperature probe into the sample ensuring that at least 40mm of the probe tip is in contact with the sample. Ensure the temperature probe is correctly plugged into the 5-pin DIN socket at the rear of the CN-200D Controller.

Note: Should the temperature probe become disconnected or fail open circuit, the display will indicate "or" and a dot next to the alarm symbol will illuminate.

7.2.2. Connect the IEC output plug to your heating apparatus as illustrated.

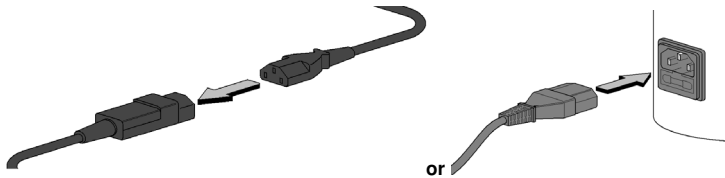

7.2.3. Connect to the mains electricity supply. Turn on using the On / Off Power switch. The amber neon will illuminate when power is being supplied to the output. Depending on the operating mode, the amber neon may be on continuously, or switch on and off.

7.3. Control Modes Explained

7.3.1. Basic On / Off Controller

The On / Off controller output has only two states. Fully on and fully off. Fully on is when the temperature is anywhere below set point, and fully off, when the temperature is anywhere above the desired set point.

7.3.2. On-Off Controller plus Hysteresis

To prevent detrimental control chattering as the temperature crosses the set point, an On / Off differential or 'hysteresis' can be added to the controller function.

When a hysteresis value is entered (for example, say 3°C), the controller will switch off once the set point temperature has been reached and will not switch back on again until the measured temperature falls 3°C below the set point.

For example, in a heating application, with a 150°C set point and a 3°C hysteresis value entered, the controller will switch off at 150°C (there may be some overshoot) and will not come back on again until the temperature falls to 147°C.

The hysteresis figure should be set to give improved control of temperature without excessive chatter. The amount of hysteresis determines the minimum temperature variation possible, although process characteristics will add to this differential.

On / Off functions are only accurate when the heating mass is relatively large, and the heater will cause overshoot and wide variations in temperature.

7.3.3. Proportional, Integral and Derivative Control (PID)

A proportional controller continuously adjusts the power, so the heat input to the process is approximately in balance with the process heat requirements in order to maintain a stable temperature. The range of temperature over which power is adjusted is from 0% to 100%. This temperature range is called the 'Proportional Band'. The proportional band is adjustable for differing process conditions (zero proportional band returns the controller to basic on / off control).





The temperature difference between the stabilised temperature and the set point is called the 'Offset'. The offset can be reduced by adjusting the integral term of the PID controller. This is achieved using the integrative action time and integrative action reset.

A derivative function can be combined with the proportional controller to provide the controller with the ability to shift the proportional band either up to or down to compensate for rapidly changing temperature (i.e. when an oven door is opened or cooler fluid is introduced into a controlled vessel). The derivative function increases the controller gain during temperature changes, and can help to reduce overshoot on start-up.



Hence, a three-mode PID controller combines the proportional, integral and derivative actions, to allow the set point temperature to be approached relatively smoothly with minimal overshoot.

7.4. Front Panel Controls

The CN-200D controller has four front panel keys as described below.

- 7.4.1. The  key is used to increase the value of the parameter shown on the display or to scroll through the parameter menu.
- 7.4.2. The  key is used to decrease the value of the parameter shown on the display or to scroll through the parameter menu.
- 7.4.3. The  key is a dual function key. It is used to display and store the value of the selected parameter when in 'Programming' mode. When used with the  it is used to display the 'Setpoint' value.
- 7.4.4. The  is an 'Exit / Stand-by button. Press of 3 seconds to turn unit on or off.

7.5. Operating Modes

- 7.5.1. The MB810B has two modes of operation: Function mode and Programming mode. The unit enters Function mode immediately following power up in auto test phase. In Function mode the display shows the temperature measured by the temperature sensing probe. The output power will also be switched on or off as appropriate. If the output power is on, the amber neon indicator on the front panel will be illuminated. The only parameter which can be altered in the function mode is the set-point. See 7.7.1.
- 7.5.2. In Programming mode, all the other parameters apart from set-point can be altered. To gain access to the programming mode from Function mode, press the keys  and . Keep them pressed for five seconds. The output power is always

off when in programming mode. If approximately 25 seconds elapse while in programming mode with out a key being pressed the CN-200D controller will activate with the last preset parameters. Furthermore by pressing the  key from any condition the unit will revert back to Function mode.

7.6. Configuration



7.6.1. Enter Programming mode as described in paragraph 7.11 The available parameters in the configuration menu are as shown in the table on pages 15 to 17.

7.6.2. Only channel 1 / output 1 is active on the CN-200D controller. Other available parameters are disabled through the factory default settings.

Please Note:- *Should any of the parameters become altered accidentally, they may be restored to their factory settings by programming the values shown on page 18.*

7.7. Entering the Set point (Channel 1 only)



7.7.1. Press and release button . Observe the display shows 1SP and the LED L1 blinks and then the associated value.

Press the  and  to set the desired value (adjustment is within the minimum SPL and maximum SPH limit).

To store the new value press button  or wait 10 seconds.

To return to operational mode without saving the settings press the  Exit / standby button.

7.8. Stand-By

7.8.1. Press the  button and wait for the 3 seconds. The word 'OFF' will be displayed. To resume press the  button once again for another 3 seconds and the display will return to normal operation.

7.9. Keypad Lock









7.9.1. The keypad lock avoids undesired and potentially dangerous operation, which might be attempted while the controller is in operation. In the INFO menu, set the parameter to LOC=Yes to inhibit all of the function buttons. To resume normal operation of the keypad, adjust the parameter setting to LOC=No. This is accessed by pressing the  and immediately releasing it.

7.10. Controller Auto-tuning in PID mode

Before commencing

7.10.1. In the setup mode (see configuration 7.6) set 1CM=PID; make sure that 1CH matches the desired operation mode (1CH=REF for refrigeration control, 1CH=HEA for heating control); then adjust set-point 1SP at the desired value.

Start Auto-tuning

7.10.2. During normal operation, keep buttons  and  pressed for 3 seconds. 1CT blinks on the display. With  +  or  pressed set the cycle time in order to define the dynamic process to be controlled. To abort the auto-tuning function, press ; to start auto-tuning press  +  or wait for 30 seconds.

During Auto-tuning

During the entire auto-tuning phase, the display alternates TUN with the actual temperature being measured. In case of power failure, when power is restored, after the initial auto-test phase, the controller resumes the auto-tune function. To abort the auto-tuning, without modifying the previous control parameters, keep button  pressed for 3 seconds. After auto-tuning has successfully taken place the controller updates the control parameters and starts to control.

Errors

If the auto-tuning function failed, the display shows an error code:

- E1 time out 1 error: the controller could not bring the temperature within the proportional band. Increase 1SP in the case of the heating control, vice versa, decrease 1SP in the case of refrigeration control and re-start the process.
- E2 time out 2 error: the auto-tuning has not ended within the maximum time allowed (1000 cycles). Re-start the auto-tuning process and set a longer cycle time 1CT.
- E3 temperature over-range: check the error was not caused by a probe malfunction, then decrease 1SP in the case of heating control or increase 1SP in the case of refrigeration control and then restart the process.
- To eliminate the error indication and return to the normal mode, press the button .

Control improvement.

- To reduce overshoot, reduce the integral reaction reset 1AR
- To increase the response speed of the system, reduce the proportional band 1PB
Caution: doing this can make the system less stable.
- To reduce swings in steady-state temperature, increase the integral action time 1IT; system stability is thus increased, although it's response speed is decreased.
- To increase the speed of the response to the variations in temperature, increase the derivative action time 1DT. Caution: a high value makes the system sensitive to small variations and it may be a source of instability.

7.11. Configuring Parameters.

7.11.1. To select the parameter, enter Programming mode by pressing and and button for 5 seconds.

Use the and buttons to select the parameter for modification.

Press the button to display the value.

By keeping the button pressed, use the and buttons to set the desired value.

When the button: is release, the newly programmed value will be stored.

The newly programmed value is stored and the following parameter is displayed.

To exit from the setup, press the or wait for 30 seconds.

	SCL	1°C; 2°C; °F	Read out scale (see Input Specification table on page 17) Caution: upon changing the SCL value, it is the absolutely necessary to reconfigure the parameters relevant to the absolute and relative temperatures (SPL, SPH, 1SP, 1HY etc.).
	SPL	-50°..SPH	Minimum limit for 1SP setting.
	SPH	SPL..150°C	Maximum limit for 1SP setting.
	1SP	SPL..SPH	Set-point (value to be maintained in the room).
	1CM	HY;PID	Control mode. With 1CM=HY you select control with hysteresis: parameters 1HY, 1T0 and 1T1 are used. With 1CM=PD you select a Proportional-Integral-Derivative control mode: parameters 1PB, 1IT, 1DT, 1AR, 1CT will be used.
	1CH	REF;HEAS	Refrigerating (REF) or Heating (HEA) control mode.
1CM=HY	1HY	0...19.9°C	OFF/ON thermostat differential. With 1HY = 0 the output is always off. On/Off refrigeration control (1CM = HY, 1CH + REF).
	1T0	0...30min	Minimum off time. After output 1 has been turned off it remains inactive for 1T0 minutes regardless of the temperature value measured.
	1T1	0...30 min	Minimum on time. (The following parameter will be 1PF). After output 1 has been turned on, it remains active for 1T1 minutes regardless of the temperature value measured.
1CM=PID	1PB	0.19.0 °C	Proportional bandwidth. Temperature control takes place by changing the ON time to the output: the closer the temperature to the set-point, the less time to activate. A small proportional band increases the promptness of the response of the system to temperature variations, but tends to make it less stable. A purely proportional control stabilises the temperature within the proportional band but does not cancel the deviation from the set-point. With 1PB=0 the output is always off.

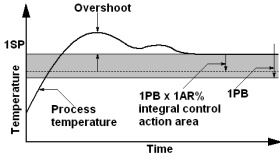
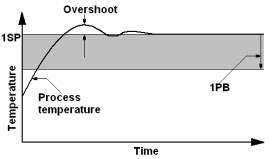
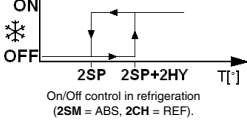
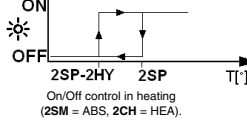
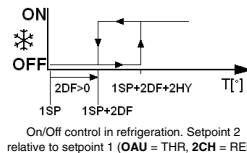
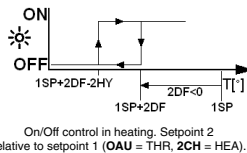
	1IT	0...999s	Integral action time. The steady-state error is cancelled by inserting an integral action. The integral action time, determines the speed with which the steady-state temperature is achieved, but a high speed (1IT low) may be the cause of the overshoot and instability in the response. With 1IT=0 the integral control is disabled	
	1DT	0...999s	Derivative action time Response overshoot may be reduced by inserting a derivative Action. A high derivative action (1DT high) makes the system very sensitive to small temperature variations and causes instability. With 1DT=0 the derivative control is disabled.	
	1AR	0..100%	Reset of integral action time referred to 1BP Decreasing the parameter 1AR reduces the integral control action zone, and consequently the overshoot (see figure on paragraph 1IT).	
	1CT	1...255s	Cycle time. It's the period in which the output ON time changes. The quicker the system to be controlled reacts to temperature variations, the smaller the cycle time must be, in order to obtain higher temperature stability and less sensitivity to load variations.	
	1PF	ON/OFF	Output state in case of probe failure.	
	*OAU	NON; THR; AL0; AL1	AUX output operation. NON: output disabled (always off). (<i>the next parameter will be ATM</i>). THR: output programmed for second thermostat control (<i>the next parameter will be 2SM</i>). AL0: contacts open when an alarm condition occurs (<i>the next parameter will be ATM</i>). AL1: contacts make when an alarm condition occurs (<i>the next parameter will be ATM</i>).	
	2SM	ABS; REL	Setpoint 2 mode. Channel 2 setpoint may be absolute (2SM=ABS), or a differential relative to setpoint 1 (2SM=REL).	
*OAU=REL	2SP	SPL....SPH	Auxiliary output switchover temperature (<i>the next parameter will be 2CH</i>).	 On/Off control in refrigeration (2SM = ABS, 2CH = REF).  On/Off control in heating (2SM = ABS, 2CH = HEA).
	2DF	-19.9+19.9°	Temperature differential relative to 1SP. The auxiliary output setpoint is equal to 1SP+2DF	 On/Off control in refrigeration. Setpoint 2 relative to setpoint 1 (OAU = THR, 2CH = REF).  On/Off control in heating. Setpoint 2 relative to setpoint 1 (OAU = THR, 2CH = HEA).
*OAU=THR	2CH	REF; HEA	Refrigerating control (REF) of heating control mode (HEA) for the auxiliary output.	
	2HY	0...19.9°	Differential of thermostat 2. With 2HY=0 the auxiliary output always remains off.	
	2T0	0...30min	Minimum off time. After output 2 has been turned off, it remains inactive for 2T0 minutes regardless of the temperature value measured.	
	2T1	0...30min	Minimum on time. After output 2 has been turned on, it remains active for 2T1 minutes regardless of the temperature value measured.	
	2PF	ON / OFF	Auxiliary output state in case of probe failure.	

*ATM		NON; ABS; REL	Alarm threshold management. NON: all temperature alarms are inhibited (<i>the following parameter will be SB</i>). ABS: the value programmed in ALM and AHA represent the real alarm thresholds. REL: the value programmed in ALR and AHR are alarm differentials referred to 1SP and 1SP+1HY
*ATM=ABS	ALA	-50° ...AHA	Low temperature alarm threshold.
	AHA	ALA +150°	High temperature alarm threshold.
*AMT=RE	ALR	-12..0°	Low temperature alarm differential. With AHR = 0 the high temperature is excluded.
	AHR	0...12.0°	High temperature alarm differential. With AHR = 0 the high temperature is excluded.
*ATD	0...120 min		Delay before alarm temperature warning.
*SB	NO / YES		Stand-by button enabling.
*INP	0mA/4mA		Sensor input selection (see table of input specifications).
*RLO	-19.9...RHI		Maximum range values. RLO takes the maximum value measured by the transmitter (i.e. the value matching 1V, 20mA)
*RHI	RLO..99.9		Maximum range values. RHI takes the maximum value measured by the transmitter (i.e. the value matching 1V, 20mA).
*OS1	-12.5..+12.5		Probe T1 offset.
*TLD	1...30min		Delay for minimum temperature (TLO) and maximum temperature (THI) logging.
*SIM	0...100		Display slowdown
*ADR	1...255		Address for PC communication.

Input Specification

Input	Range [Measurement Accuracy]		
	SCL=1°C	SCL=2°C	SCF=°F
PT100	-50/-19.9÷99.9/150°C [<±0.3°C]	-100÷850°C [<±1°C(-50÷850°),±2°C]	-150÷999°F [<±2°F(-60÷999°),±4°F]

NOTE: Certain times are not used on the CN-200D configuration and should be left set at the manufactured default setting.

8. TECHNICAL SPECIFICATION

Mains supply voltage	110-120V~AC 50/60 Hz – (CN-200D-115, MKII) 220-240V~AC 50/60 Hz – (CN-200D, MKII)
Maximum load	115V = 1000 Watts 230V = 2000 Watts
Controller power consumption	115V = 2W 230V = 2W
Fuse rating	115V = F10A 20mm x 5mm Glass Quickblow 230V = F10A 20mm x 5mm Glass Quickblow
Relay output	12A switching Note: 12A not available for use. The unit is fused at 10A see max load – Watts
HH179(S)	Mains cord and moulded IEC plug and lead set cable (UK) 10A BS1362
HH180(S)	Mains cord and moulded IEC plug and lead set cable (Europe)
CRM6288	Mains cord and moulded IEC plug and lead set cable (USA)
Mains Output	Non-detachable 3-core mains cable with moulded IEC socket (230V) or USA socket (115V)
Temperature Probe Input	5-pin DIN socket
Rod Clamp size	12.7mm diameter
Output ON Indication	Amber Neon (front panel)
Case Construction	Die cast Aluminium
On / Off control	Rocker Switch

**Do not allow this product to come into contact with liquid.
The Ingress protection rating for this product is classified as IPX0.**

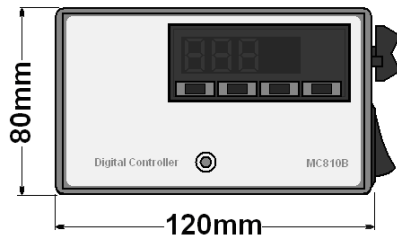
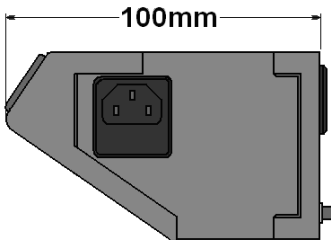

Weight 1.1Kg.

9. MAINTENANCE

9.1. General Information.



Unplug the unit from the mains voltage supply before undertaking any maintenance tasks.



Maintenance should only be carried out under the direction of the Responsible Body, by a competent electrician. Failure to do so may result in damage to the product and in extreme cases be a danger to the end user.

With proper care in operation this equipment has been designed to give many years of reliable service. Contamination or general misuse will reduce the effective life of this product and may cause a hazard.

Maintenance for the unit should include:

- Periodic electrical safety testing (an annual test is recommended as the minimum requirement).
- Regular inspection for damage with particular attention to the mains lead and plug set.
- Routine cleaning of the equipment should be undertaken using a clean cloth.

DO NOT USE SOLVENTS FOR CLEANING ANY PART OF THIS EQUIPMENT.

9.2. Fuse Replacement.

The mains fuse holder is located at the side of this product. Refer to 'Fuse Rating' in the Technical Specification section for correct fuse type and rating. Turn your product off and remove it from the mains supply. Open fuse draw and remove fuses. Fit replacement fuses and close the draw.

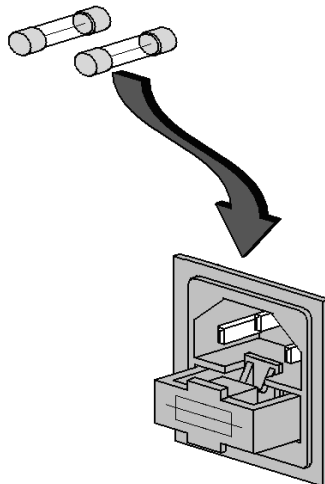





















9.3. Servicing

This product should be serviced by a Antylia Scientific Service Engineer or by an agent on behalf of Antylia Scientific Limited. If in doubt contact Antylia Scientific. See Section 11.

9.4. Calibration

9.4.1. Recalibration

- Have a precision reference thermometer of calibrator to hand. Ensure that OS1=0 and SIM = 0.
- Switch the controller off and on again.   
- During the auto-test phase, press buttons  +  and keep them pressed until the  led sh .
- With buttons  and  selected OAD or SAD; OAD allows a calibration of 0, inserting a constant corrective over the whole scale of measurement. SAD allows a calibration of the top part of the measurement scale with a proportional correction between  calibration point and 0.   
- Press  to display the value and then use  +  or  to make the read value coincide with the value   by the reference instrument.
- Exit from calibration by pressing button .

9.5. Spillage and Decontamination

In the event of spillage switch off and unplug this product from the mains electrical supply. Wipe off all excess liquid from the unit and surrounding area using an absorbent soft cloth.

If in doubt please consult Customer Support. Refer to section 11.



If the equipment has been exposed to contamination, the Responsible Body is responsible for carrying out appropriate decontamination. If hazardous material has been spilt on or inside the equipment, decontamination should only be undertaken under the control of the Responsible Body with due recognition of possible hazards. Before using any cleaning or decontamination method, the Responsible Body should check with the manufacturer the proposed method will not damage the equipment.

Prior to further use, the Responsible Body shall check the electrical safety of the unit. Only if all safety requirements are met can the unit be used again. The above procedure is intended as a guide. Should spillage occur with a toxic or hazardous fluid then special precautions may be necessary.

Decontamination Certificate.

Note: In the event of this equipment or any part of the unit becoming damaged, or requiring service, the item(s) should be returned to the manufacturer for repair accompanied by a completed decontamination certificate. **Copies of the Certificate are available from Distributor/Manufacturer.**

At the end of life, this product must be accompanied by a completed Decontamination Certificate.

10. SPARES AND ACCESSORIES

Order Number	Description
HH179(S)	Mains cord and moulded IEC plug and lead set cable (UK) 10A BS1362
HH180(S)	Mains cord and moulded IEC plug and lead set cable (Europe)
CRM6288	Mains cord and moulded IEC plug and lead set cable (USA)
AZ6705	Temperature probe 250°C max
AZ6706	Temperature probe 400°C max
AZ6741	Temperature probe 800°C max

Please contact your local sales specialist or email cpspars@antylia.com to enquire about available spares.

Please visit www.Cole-Parmer.com for a full list of available accessories.

11. CUSTOMER AND TECHNICAL SUPPORT

For help and support in using this product, please contact Customer Services at the following address:

Antylia Scientific Ltd.
Beacon Road,
Stone,
Staffordshire,
ST15 0SA,
United Kingdom
Tel: +44 (0)1785 812121

Service: cpsservice@antylia.com
General enquiries: cpinfo@antylia.com
Order enquiries: cpsales@antylia.com
Technical support: cptechsupport@antylia.com

www.coleparmer.com

12. NOTES

 This product meets the applicable CE Directives and UKCA Legislation for radio frequency interference and may be expected not to interfere with, or be affected by, other equipment with similar qualifications. We cannot be sure that other equipment used in its vicinity will meet these standards and so we cannot guarantee

that interference will not occur in practise. Where there is a possibility that injury, damage or loss might occur if equipment malfunctions due to radio frequency interference, or for general advise before use, contact the manufacturer.

Declaration of Conformity is available to view online at www.coleparmer.com

EU Representative address

Antylia Scientific GmbH
Futtererstraße 16
97877 Wertheim
Deutschland
Tel: +49 9377 9203-0
Email: sales@coleparmer.de

UK Representative address

Antylia Scientific
9 Orion Court
Ambuscade Road
Colmworth Business Park
St. Neots
PE19 8YX
United Kingdom
Tel: +44 (0) 1480 277339
Email: enquiries@antylia.com

Ordering Information

Order No.	Series	Model	Legacy SKU
32587-00	CN-200D	CN-200D	MC810B
32587-01	CN-200D	CN-200D-115	MC810BX1

Warranty Registration



UK

T: +44 (0) 1480 272279
E: uk.sales@antylia.com
W: coleparmer.co.uk

Germany

T: +49 (0) 9377 92030
E: de.sales@antylia.com
W: coleparmer.de

France

T: +33 (0) 1486 37800
E: fr.sales@antylia.com
W: coleparmer.fr

Italy

T: +39 (0) 284349215
E: it.sales@antylia.com
W: coleparmer.it

India

T: +9122 61394444
E: info@coleparmer.in
W: coleparmer.in

China

T: +1 847 549 7600
E: sales@antylia.com
W: coleparmer.com

USA

T: +1 847 549 7600
E: sales@antylia.com
W: coleparmer.com

Canada

T: +514 355 6100
E: info@antylia.ca
W: coleparmer.ca

Other

T: +1 847 549 7600

Cole-Parmer®
essentials

Antylia Scientific Ltd.
Beacon Road,
Stone,
Staffordshire,
ST15 0SA,
United Kingdom

